

## LIQUID SOAP DISPENSER WP174-2 FOR MOUNTING BEHIND FIXED MIRROR



91 x 259(221) x 98 mm

500 ml or 950 ml soap bottle or 850 ml plug-in tank

- Liquid soap dispenser in robust, germ-reducing and easy-care stainless steel (AISI 316L).
- For mounting behind fixed mirror on site.
- One-hand operated and non-drip soap pump.
- Designed for standard 500 ml or 950 ml disposable bottles of liquid soap or hand lotion. Accessible for refilling through spring stop pin and by removing from below.
- Also refillable with large container using the plug-in tank as an option.
- Wear parts can be replaced as modules.
- Mounting: With two screws through key holes and one optional anti-theft hole in the back wall.  
Depth of substructure installation: min. 130 mm  
Height above vanity unit: min. 220(250) mm
- Delivery includes fixing material, self-adhesive information label „Soap“ and first fill with soap.
- Weight, including single package: 1.5 kg



### Suggested text for specifications:

Liquid soap dispenser in stainless steel (AISI 316L) for mounting behind fixed mirror. One-hand operated and non-drip soap pump. Designed for standard 500 ml or 950 ml disposable bottles of liquid soap or hand lotion. Accessible for refilling through spring stop pin and by removing from below. Delivery includes fixing material, self-adhesive information label „Soap“ and first fill with soap.

Dimensions: 91 x 259(221) x 98 mm

Article No. WP174-2

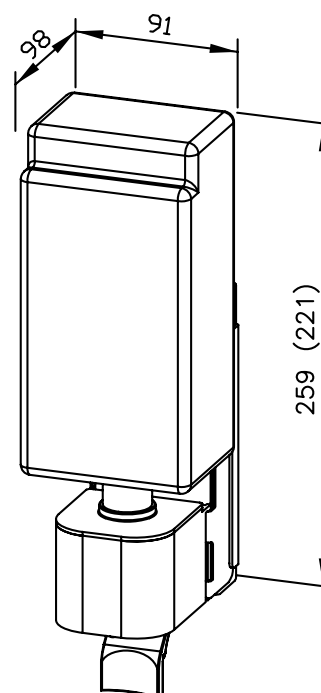

| Options             | ID No.  |
|---------------------|---------|
| Plug-in tank 850 ml | 937 201 |
| Available surface   | ID No.  |
| satin finished      | 727 036 |

### Ernst Wagner GmbH & Co. KG

Ernst-Abbe-Straße 21 · D-72770 Reutlingen · Tel.: +49712151539-0 · Fax: -20  
info@wagner-ewar.de · www.wagner-ewar.de

WAGNER  
E W A R